

TEST REPORT

Lucideon Reference: 142218 (QT-30072/3/SL)/Ref. 5

Project Title: Testing of OnLevel Glass Balustrade System to BS 6180:2011 - System 6010

Client: OnLevel BV
Innovatielaan 25
Heerenveen
8447 SN
The Netherlands

For the Attention of: Iwan Oude Luttikhuis

Author(s): Miss Lisa Cobden

Report Date: 30 June, 2014

Purchase Order No.: 24000070

Work Location: Lucideon UK



Miss Joanne Booth
Consultancy Team
Reviewer



Miss Lisa Cobden
Consultancy Team
Project Manager

CONTENTS

	Page
1 INTRODUCTION	3
2 TEST SAMPLES	3
3 TEST PROGRAMME	3
4 TEST METHOD	3
5 RESULTS	4
TABLES	5-6
PLATE	7
CHART	8
APPENDIX: Figures	

LSC/LMP/N14TRE35
30.06.14

1 INTRODUCTION

Lucideon were commissioned by the client, OnLevel, to carry out load testing in accordance with BS 6180:2011 Barriers in and about buildings, to allow their balustrade system to be classified for use in accordance with BS 6180:2011 Barriers in and about buildings – Code of Practice.

The testing was carried out at OnLevel's facilities at Innovatielaan 25 8447 SN Heerenveen The Netherlands.

This report summarises the test results obtained during the test programme and does not provide interpretation of those results.

2 TEST SAMPLES

The aluminium channel tested was designated as System 6010. The system is shown in Figure 1.

The channel was installed by OnLevel personnel.

3 TEST PROGRAMME

A horizontal line load was carried out on the aluminium channel with the following glass types installed:

- Laminated Tempered Glass with PVB Foil 8 8 4 – size (w x h):1000 mm x 1085 mm.
- Laminated Tempered Glass with PVB Foil 10 10 4 – size (w x h):1000 mm x 1100 mm.
- Monolithic Tempered 19 mm – size (w x h): 1000 mm x 1100 mm.
- Monolithic Tempered 15 mm – size (w x h): 1000 mm x 1100 mm.

4 TEST METHOD

The channel was bolted to the top of a concrete block, nominally 0.5 m x 0.5 m x 3.5 m which was fixed to the floor of the test facility. The 1.0 m length of channel was bolted to the block at 150 mm centres by the client using the appropriate fixings (see Figure 1).

The appropriate thickness glass panel was fitted into the channel using 'Flex Fit' fixing clips at nominally 300 mm centres such that the plastic clip was to the outside face of the glass, (see Figures 2 and 3).

A horizontal imposed line load was applied to the glass at a height of 1.1 m above the datum level of the floor and the deflection measured at the top central point of the panel 1.1 m above the datum level of the floor. The load was applied via a hydraulic ram and the deflection measured using a digital electronic displacement transducer, (see Plate 1).

5 RESULTS

The test was carried out in accordance with the guidance given in BS 6180 Barriers in and about buildings – Code of Practice. The standard states that the maximum allowable deflection for a free standing glass protective barrier panel is 25 mm.

Table 2 of BS 6180 Barriers in and about buildings – Code of Practice categorises parapets, barriers and balustrades for areas of use depending on the loads they have achieved under testing.

The loads achieved by the OnLevel glazing system tested under horizontal imposed line load to the maximum deflection of 25 mm are given in Table 1.

All figures quoted in Table 1 contain no safety factors and are direct loads as achieved by the system under test conditions.

Table 2 summarises the suitability of the tested systems in accordance with Table 2 of BS 6180:2011.

NOTE: The results given in this report apply only to the samples that have been tested.

END OF REPORT

Table 1: Summary of Performance of OnLevel Balustrade System
Tested under Horizontal Imposed Line Load

Base Rail	Glass	Imposed Line Load at 25 mm Deflection (kN/m)	Working Line Load for System (kN/m)	Deflection at Working Line Load for System (mm)
System TL6010	8 8 4	0.88	0.74	20.34
	10 10 4	0.92	0.74	19.53
	19 mm	1.28	0.74	10.69
	15 mm	1.12	0.74	17.27

Table 2: Summary of Suitability of OnLevel Balustrade Systems in Accordance with Table 2 of BS 6180:2011

Type of Occupancy for Part of the Building	Examples of Specific Use	Horizontal Uniformly Distributed Line Load (kN/m)	TL-6010			
			8 8 4	10 10 4	19 mm	15 mm
Domestic and residential activities	(i) all areas within or serving exclusively one single family dwelling including stairs, landings, etc but excluding external balconies and edges of roofs	0.36	✓	✓	✓	✓
	(ii) other residential, i.e. houses of multiple occupancy and balconies, including Juliette balconies and edges of roofs in single family dwellings	0.74	✓	✓	✓	✓
Offices and work areas not included elsewhere, including storage areas	(iii) light access stairs and gangways not more than 600 mm wide	0.22	✓	✓	✓	✓
	(iv) light pedestrian traffic routes in industrial and storage buildings except designated escape routes	0.36	✓	✓	✓	✓
	(v) areas not susceptible to overcrowding in office and institutional buildings, also industrial and storage buildings except as given above	0.74	✓	✓	✓	✓
Areas where people might congregate	(vi) areas having fixed seating within 530 mm of the barrier, balustrade or parapet	1.50	X	X	X	X
Areas with tables or fixed seating	(vii) restaurants and bars	1.50	X	X	X	X
Areas without obstacles for moving people and not susceptible to overcrowding	(viii) stairs, landings corridors ramps	0.74	✓	✓	✓	✓
	(ix) external balconies including Juliette balconies and edges of roofs; footways and pavements within building cartilage adjacent to basement/sunken areas	0.74	✓	✓	✓	✓
Areas susceptible to overcrowding	(x) footways or pavements less than 3 m wide adjacent to sunken areas	1.50	X	X	X	X
	(xi) theatres, cinemas, discotheques, bars, auditoria, shopping malls, assembly areas, studios; footways or pavements greater than 3 m wide adjacent to sunken areas	3.00	X	X	X	X
	(xii) grandstands and stadia	(Note 1)	-	-	-	-
Retail areas	(xiii) all retail areas including public areas of banks/building societies or betting shops	1.50	X	X	X	X
Vehicular	(xiv) pedestrian areas in car parks, including stairs, landings, ramps, edges of internal floors, footways, edges of roofs	1.50 (Note 2)	X	X	X	X
	(xv) horizontal loads imposed by vehicles	(Note 2)	-	-	-	-

Note 1 – See requirements of the appropriate certifying authority

Note 2 – Clause 8.1.1 of BS 6180:2011 states that “glass should not be used for vehicle protection barriers”



Plate 1: Generic Test Arrangement

Chart 1: Load Versus Deflection Curves for OnLevel Balustrades System TL6010

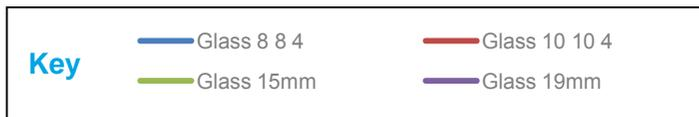
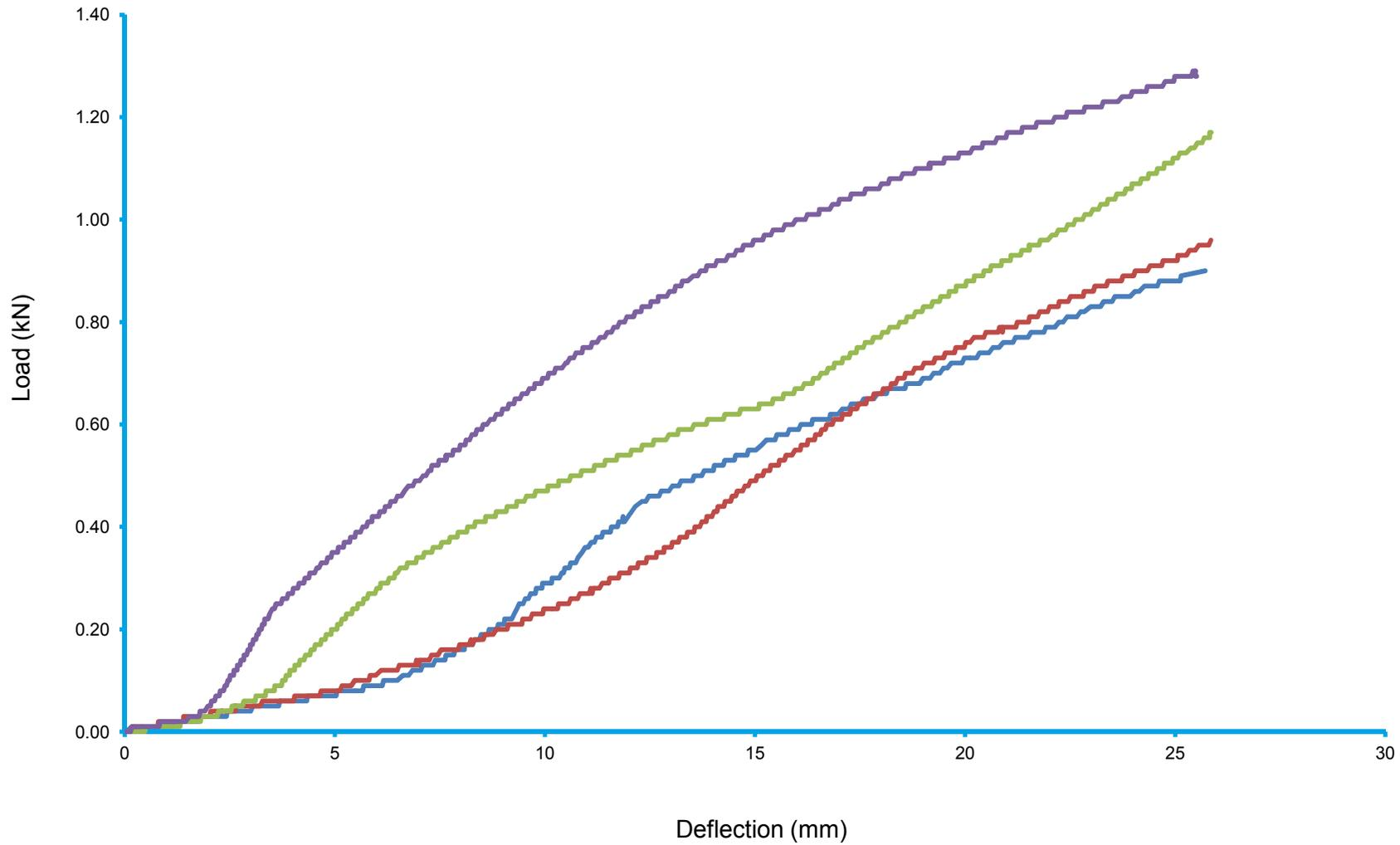

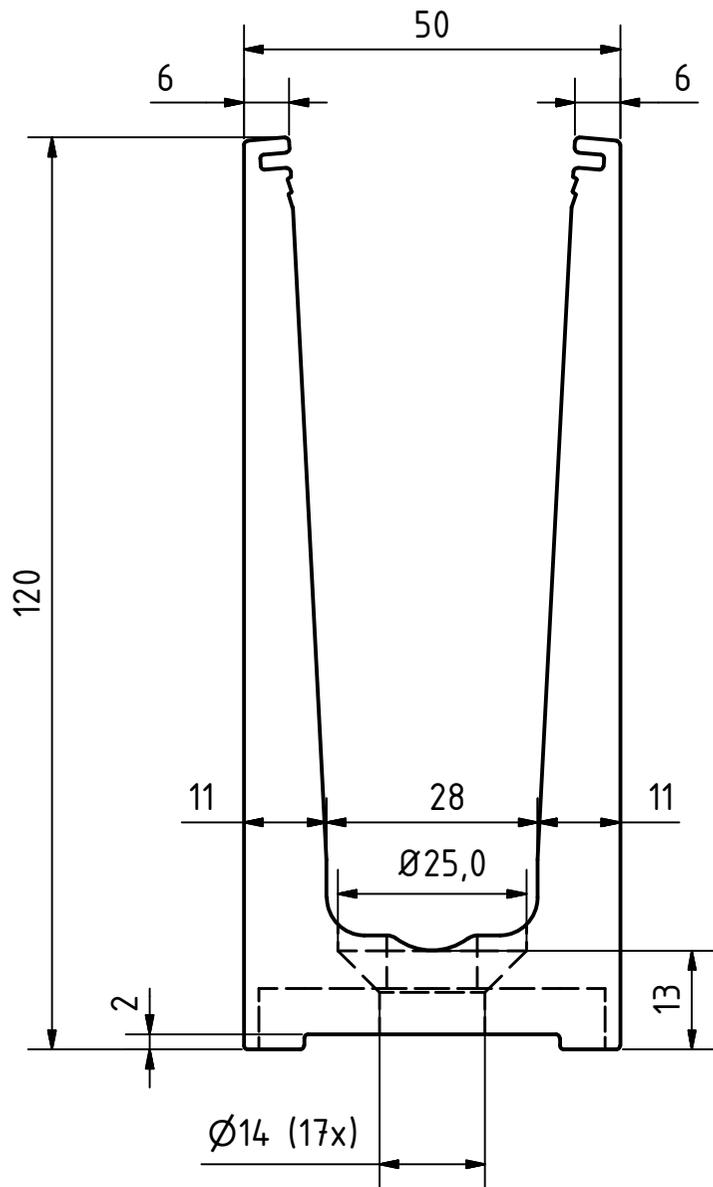

Detail dewatering hole (3x)
(distance approx. 1000mm)

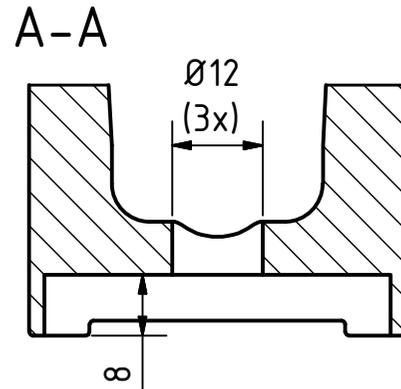

3D

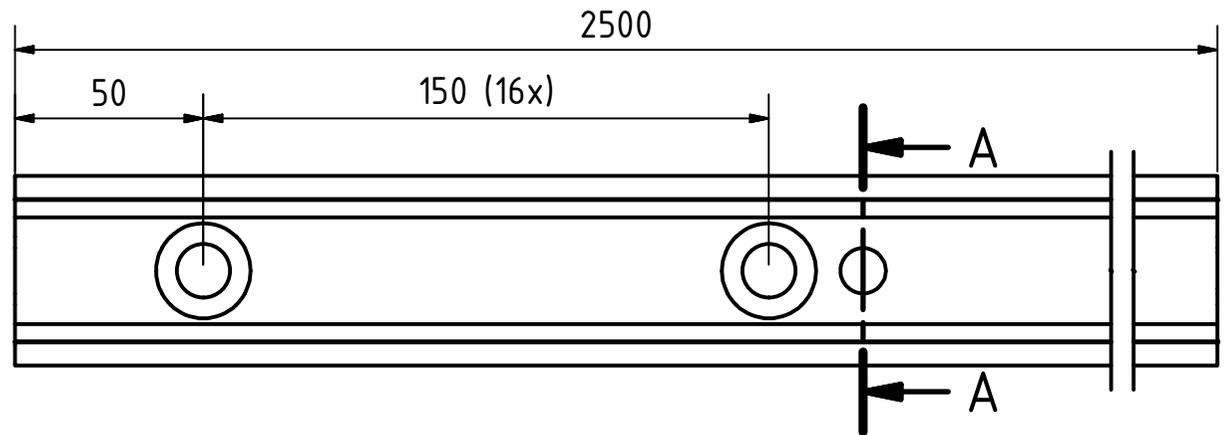
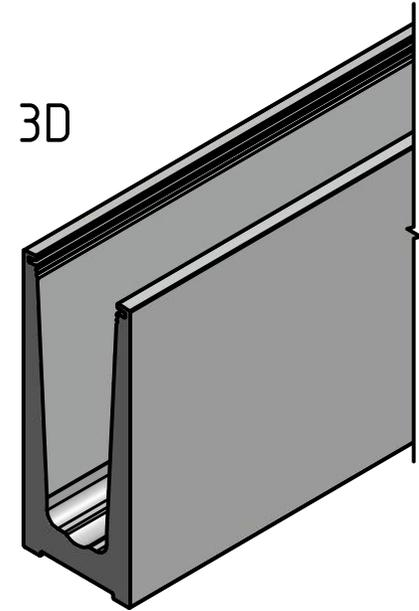

Material: Aluminum
Surface: natural anodized

Designed by IOL	Created 27-1-2014	Modified	Comment
		Part TL-6010 L=2500mm	
		Tekeningnummer 10601000211	Size A4

Exploded view

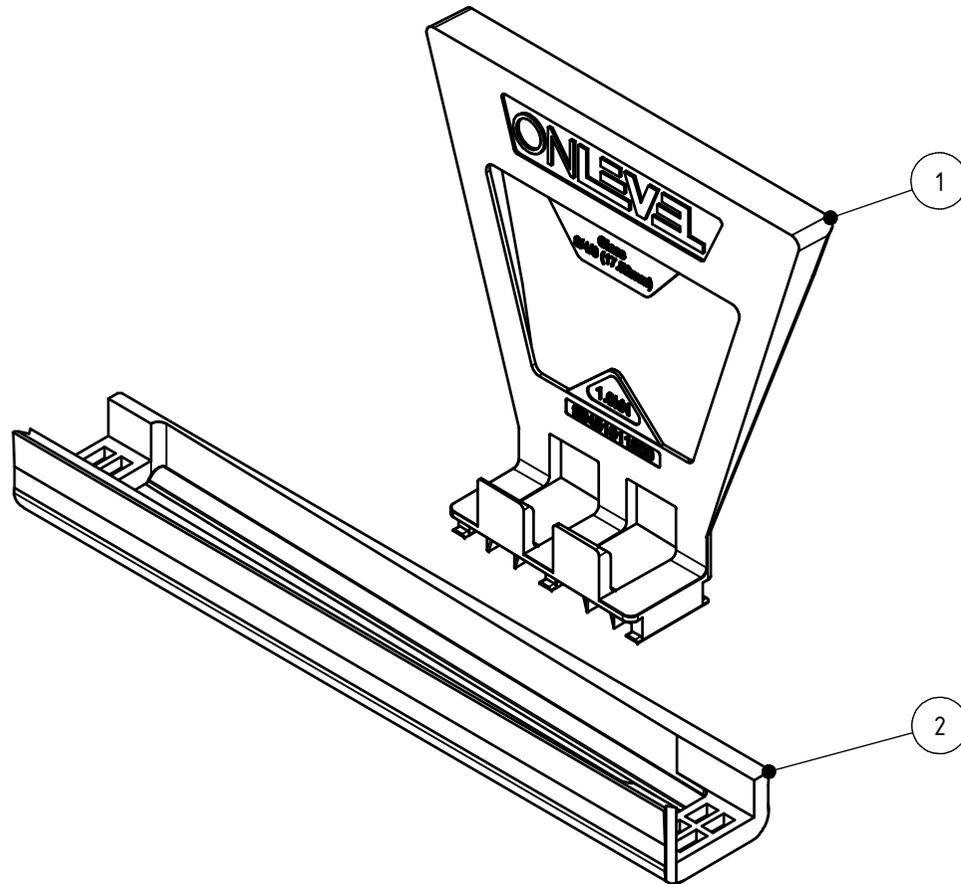

Assembled view

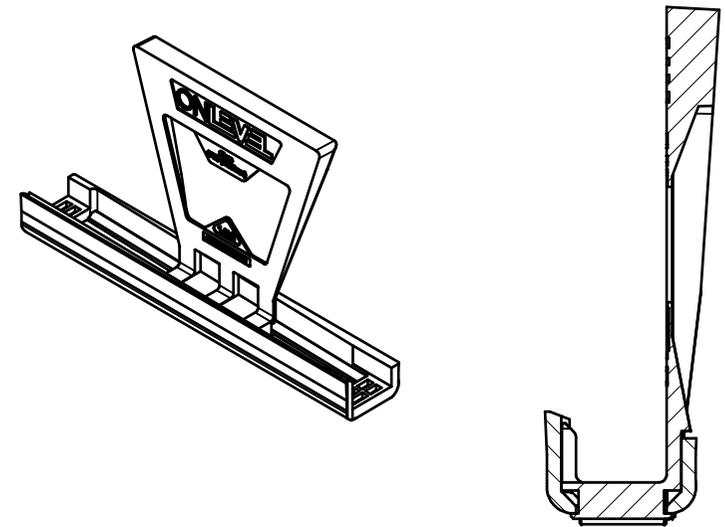

PARTS LIST			
ITEM	QTY	PART NUMBER	DESCRIPTION
1	1	99451011800	Glass carrier 1.0kN Glass 17.52 mm
2	1	99452013000	Glassboat 1.0kN Glass 15mm-17.52mm
Designed by IOL		Created 4-11-2013	Modified Comment
		Part Glass carrier set 1kN Glass 8/4/8 (17.52mm)	
		Tekeningnummer 99450011800	Size A3

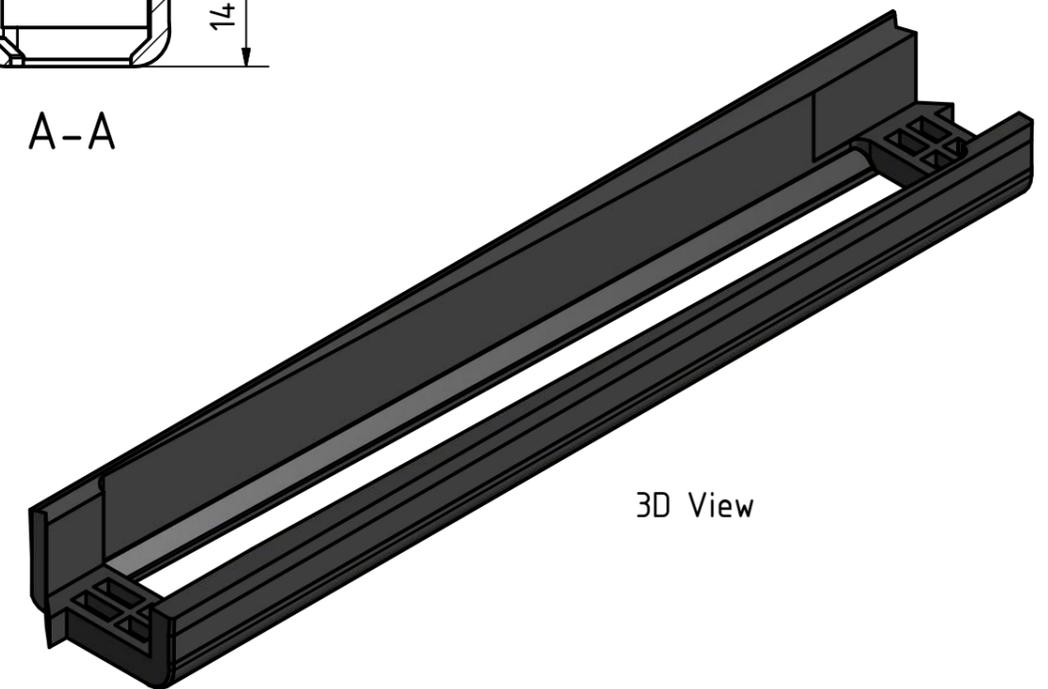
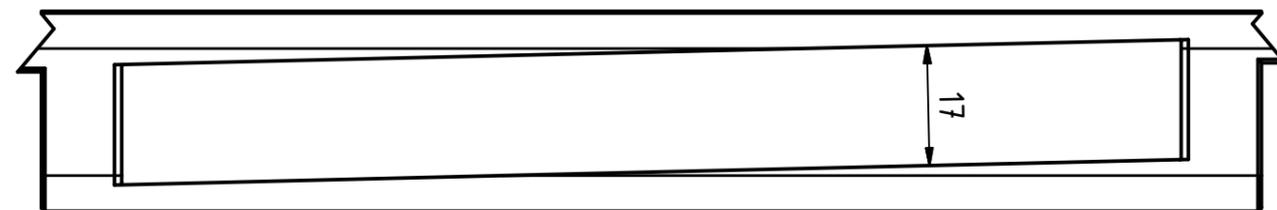
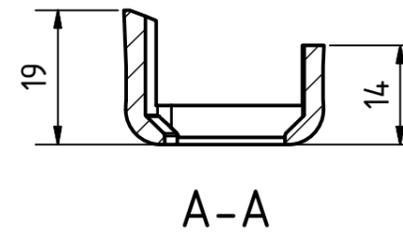
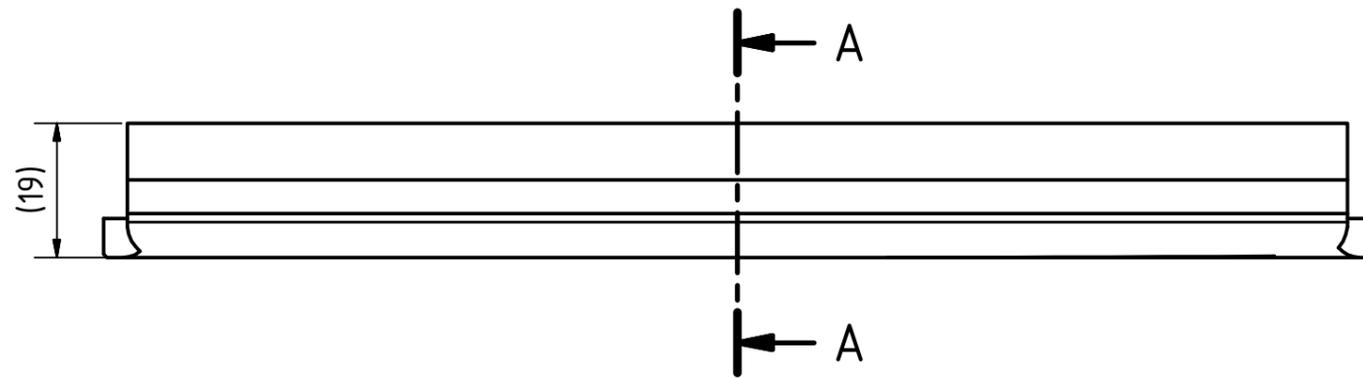
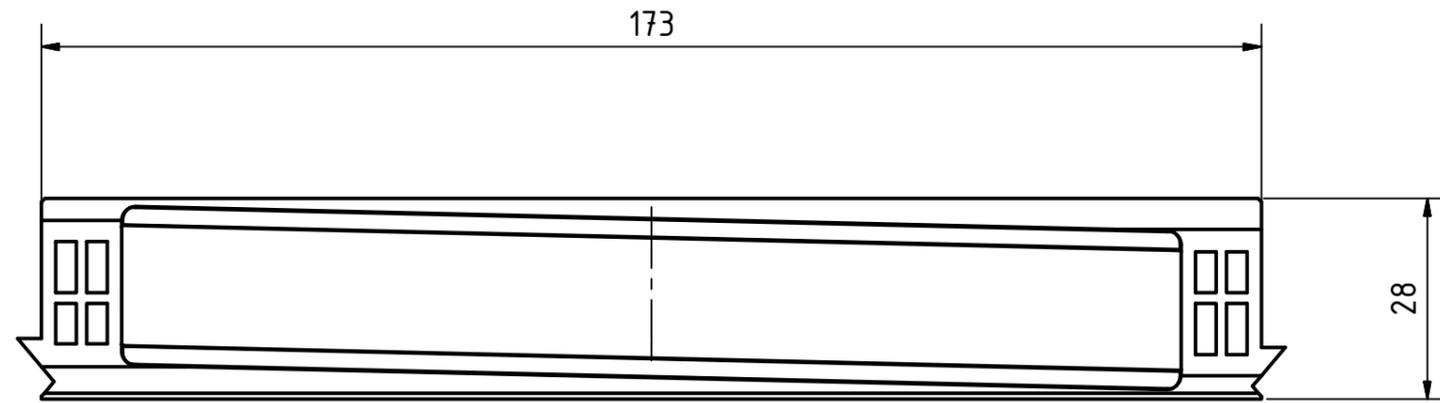

Material: ABS-GF30

Designed by IOL	Created 4-11-2013	Modified	Comment	
		Part Glassboat 1.0kN Glass 15mm-17.52mm		
		Tekeningnummer 99452013000	Size A3	Scale 1 : 1